



aerospace
climate control
electromechanical
filtration
fluid & gas handling
hydraulics
pneumatics
process control
sealing & shielding



Stainless Steel Air Preparation Units

Filters, Regulators, Lubricators

Catalog 0717-E



ENGINEERING YOUR SUCCESS.



Global Pneumatics

This icon can be found next to products that are widely supported by Parker Pneumatics' worldwide manufacturing and sales network. When you see this icon, you can be confident that this product is manufactured and/or stocked* worldwide for rapid delivery. In addition to local manufacturing or inventory, our sales network has been specifically trained on these products to provide our customers with the best possible service.

Products not showing this icon are still sold and distributed worldwide. However, The Global Pneumatics icon represents products that customers can expect the best level of support.

If you are a multi-national company, seek global sourcing or ship globally, depend on Parker Pneumatic for **PREMIER CUSTOMER SERVICE**.

* Stocking levels vary by country

WARNING

FAILURE OR IMPROPER SELECTION OR IMPROPER USE OF THE PRODUCTS AND/OR SYSTEMS DESCRIBED HEREIN OR RELATED ITEMS CAN CAUSE DEATH, PERSONAL INJURY AND PROPERTY DAMAGE.

This document and other information from Parker Hannifin Corporation, its subsidiaries and authorized distributors provide product and/or system options for further investigation by users having technical expertise. It is important that you analyze all aspects of your application including consequences of any failure, and review the information concerning the product or system in the current product catalog. Due to the variety of operating conditions and applications for these products or systems, the user, through its own analysis and testing, is solely responsible for making the final selection of the products and systems and assuring that all performance, safety and warning requirements of the application are met.

The products described herein, including without limitation, product features, specifications, designs, availability and pricing, are subject to change by Parker Hannifin Corporation and its subsidiaries at any time without notice.

Offer of Sale

The items described in this document are hereby offered for sale by Parker Hannifin Corporation, its subsidiaries or its authorized distributors. This offer and its acceptance are governed by the provisions stated on the separate page of this document entitled "Offer of Sale".

Table of Contents

Product Selection Chart	3
Air Line Filters	
Miniature PF504.....	4-5
Standard PF10.....	6-7
Air Line Coalescing Filters	
Miniature PF501.....	8-9
Standard PF11.....	10-11
Air Line Regulators	
Miniature PR354, PR364	12-13
Standard PR10, PR11	14-15
Filter / Regulator	
Miniature PB548, PB558.....	16-17
Standard PB11, PB12.....	18-19
Air Line Lubricators	
Standard PL10.....	20-21

Product Selection Chart

Basic Unit	Series	Port Size		Bowls	Capacity	Elements (Micron)			Page
		1/4	1/2			5	20	40	
FILTERS	PF504	X	—	316 Stainless Steel	1 oz.	Opt.	Std.	—	B4-B5
	PF10	—	X	316 Stainless Steel	4 oz.	Opt.	—	Std.	B6-B7
COALESCING FILTERS	PF501	X	—	316 Stainless Steel	1 oz.	.3 Micron			B8-B9
	PF11	—	X	316 Stainless Steel	4 oz.	.3 Micron			B10-B11

Basic Unit	Series	Port Size		Spring Range				Page
		1/4	1/2	25	60	125	250	
REGULATORS	PR354	X	—	Std.	Std.	Std.	—	B12-B13
	PR364	X	—	Std.	Std.	Std.	—	
	PR10	—	X	—	Std.	Std.	Opt.	B14-B15
	PR11	—	X	—	Std.	Std.	Opt.	

Basic Unit	Series	Port Size		Bowls	Capacity	Elements (Micron)			Spring Range				Page
		1/4	1/2			5	20	40	25	60	125	250	
FILTER / REGULATORS	PB548	X	—	316 Stainless Steel	1 oz.	Opt.	Std.	—	Opt.	Opt.	Std.	—	B16-B17
	PB558	X	—	316 Stainless Steel	1 oz.	Opt.	Std.	—	Opt.	Opt.	Std.	—	
	PB11	—	X	316 Stainless Steel	4 oz.	Opt.	—	Std.	—	Opt.	Std.	Opt.	B18-B19
	PB12	—	X	316 Stainless Steel	4 oz.	Opt.	—	Std.	—	Opt.	Std.	Opt.	
LUBRICATORS	PL10	—	X	316 Stainless Steel	4 oz.							B20-B21	



PF504 Filter – Miniature

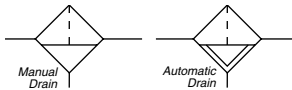

Features

- Stainless steel construction handles most corrosive environments.
- Fluorocarbon seals standard.
- Meets NACE specifications MR-01-75/ISO 15156.
- 1/8" female threaded drain.
- High Flow: 1/4" - 23 SCFM[§]

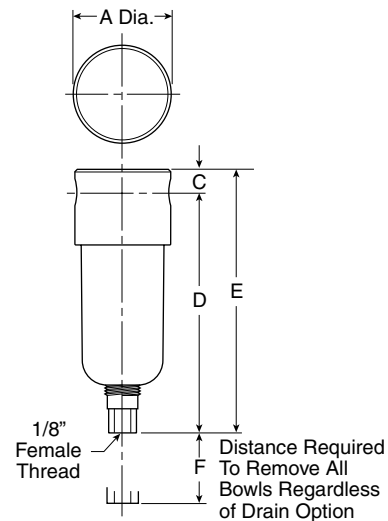

Port Size	NPT	BSPB
	Manual Twist Drain	Manual Twist Drain
1/4"	PF504-02DHSS	PF504G02DHSS

Standard part numbers shown bold.

For other models refer to ordering information below.

SCFM = Standard cubic feet per minute at 90 PSIG inlet and 5 PSIG pressure drop.

PF504 Filter Dimensions		
A	C	D
1.56 (40)	0.31 (8)	3.69 (94)
E	F	
4.00 (102)	1.58 (40)	

inches
(mm)

Ordering Information

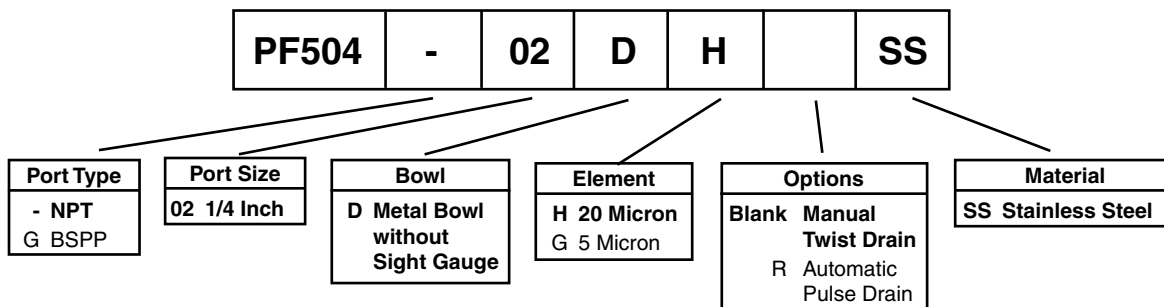

BOLD ITEMS ARE MOST POPULAR.





Operation

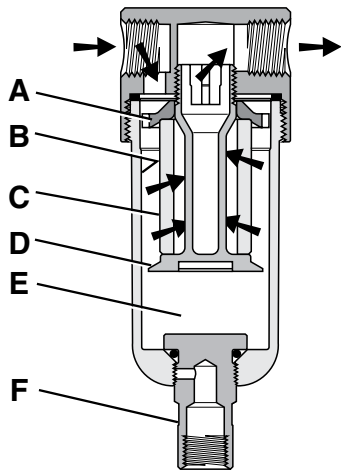

First Stage Filtration:

Air enters at inlet port and flows through deflector plate (A) which causes a swirling action. Liquids and coarse particles are forced to the bowl interior wall (B) by the centrifugal action of the swirling air. They are then carried down the bowl wall by the force of gravity. The baffle (D) separates the lower portion of the bowl into a “quiet zone” (E) where the removed liquid and particles collect, unaffected by the swirling air, and are therefore not reentrained into the flowing air.

Second Stage Filtration:

After liquids and large particles are removed in the first stages of filtration, the air flows through element (C) where smaller particles are filtered out. The filtered air then passes downstream. Collected liquids and particles in the “quiet zone” (E) should be drained before their level reaches a height where they would be reentrained in the flowing air. This can be accomplished by unscrewing the drain valve (F) slightly until the liquid begins to drain.

Technical Information

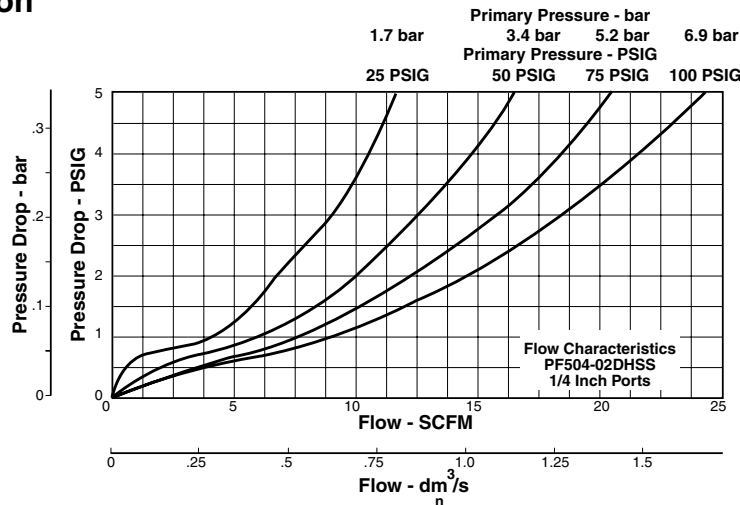

PF504 Filter Kits & Accessories

- Drain Kits –**
 - Automatic Pulse Drain RK504SY-SS
 - Manual Twist Drain–
 - Small (Old) SA600Y7-1SS
 - Large (New) SAP05481
- Filter Element Kits –**
 - Particulate (5 Micron) EK504VY
 - Particulate (20 Micron) EK504Y
- Pipe Nipple –**
 - 1/4" 316 Stainless Steel 616Y28-SS

Specifications

- Bowl Capacity** 1.0 Ounces
- Filter Rating** 20 Micron
- Sump Capacity** 0.4 Ounce
- Port Threads** 1/4 Inch

Pressure & Temperature Ratings –

- Manual Twist Drain 0 to 300 PSIG (0 to 20.7 bar)
 0°F to 180°F (-18°C to 82°C)
- Auto Pulse Drain..... 10 to 175 PSIG (0 to 12 bar)
 32°F to 150°F (0°C to 66°C)

Note: Air must be dry enough to avoid ice formation at temperatures below 32°F (0°C)

Weight 0.6 lb. (0.27 kg)

Materials of Construction

- Body** 316 Stainless Steel
- Bowls** 316 Stainless Steel
- Deflector** Acetal
- Drain** 316 Stainless Steel
- Element Holder** Acetal
- Filter Element** Polyethylene
- Seals** Fluorocarbon



PF10 Filter – Standard

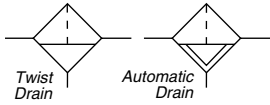

Features

- Stainless steel construction handles most corrosive environments.
- Meets NACE specifications MR-01-75/ISO 15156.
- 1/8" female threaded drain.
- High Flow: 1/2" - 70 SCFM[§]

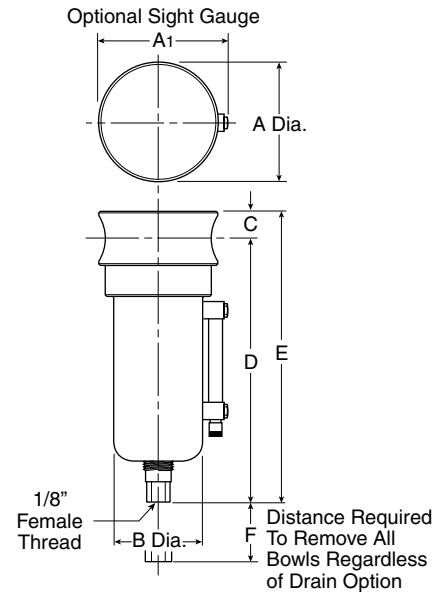

Port Size	NPT		BSPP	
	Manual Twist Drain	Automatic Float Drain	Manual Twist Drain	Automatic Float Drain
1/2"	PF10-04WJSS	PF10-04WJRSS	PF10G04WJSS	PF10G04WJRSS

PF10 Filter Dimensions		
A 2.38 (60)	A1 2.50 (64)	B 1.75 (44)
C .56 (14)	D 5.00 (127)	E 5.56 (141)
F 2.12 (54)		

inches
(mm)

Standard part numbers shown bold.

For other models refer to ordering information below.

SCFM = Standard cubic feet per minute at 90 PSIG inlet and 5 PSIG pressure drop.

Ordering Information

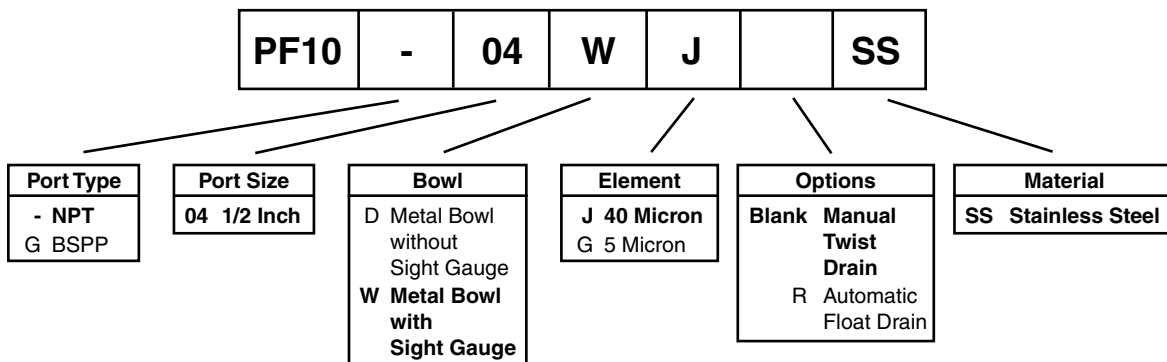

BOLD ITEMS ARE MOST POPULAR.





Operation

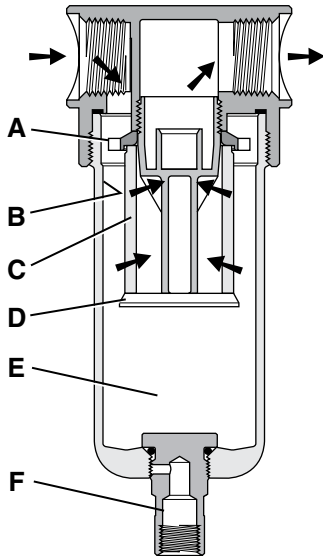

First Stage Filtration:

Air enters at inlet port and flows through deflector plate (A) which causes a swirling action. Liquids and coarse particles are forced to the bowl interior wall (B) by the centrifugal action of the swirling air. They are then carried down the bowl wall by the force of gravity. The baffle (D) separates the lower portion of the bowl into a “quiet zone” (E) where the removed liquid and particles collect, unaffected by the swirling air, and are therefore not reentrained into the flowing air.

Second Stage Filtration:

After liquids and large particles are removed in the first stages of filtration, the air flows through element (C) where smaller particles are filtered out. The filtered air then passes downstream. Collected liquids and particles in the “quiet zone” (E) should be drained before their level reaches a height where they would be reentrained in the flowing air. This can be accomplished by unscrewing the drain valve (F) slightly until the liquid begins to drain.

Technical Information

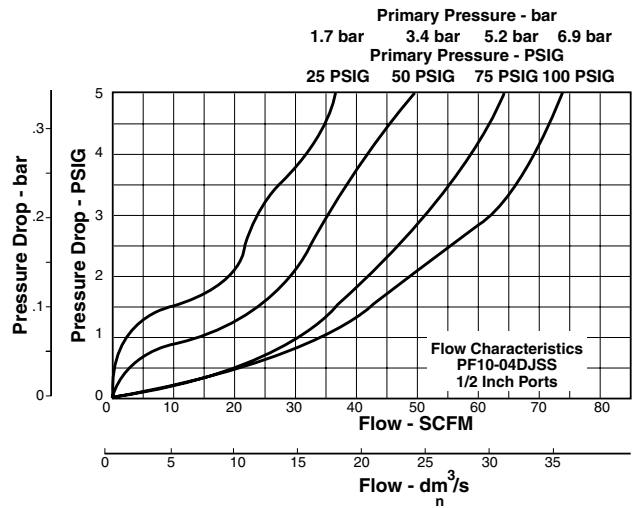

PF10 Filter Kits & Accessories

Drain Kit –

- Automatic Float Drain SA10MDSS
- Manual Twist Drain–
- Small (Old) SA600Y7-1SS
- Large (New) SAP05481

Filter Element Kits –

- Particulate (40 Micron) EK55J
- Particulate (5 Micron) EK55G

Pipe Nipple – 1/2" 316 Stainless Steel 616A28-SS

Specifications

- Bowl Capacity 4.0 Ounces
- Filter Rating 40 Micron
- Sump Capacity 1.7 Ounce
- Port Threads 1/2 Inch
- Pressure & Temperature Ratings –
- Manual Twist Drain (D) 0 to 300 PSIG (0 to 20.7 bar)
- 0°F to 180°F (-18°C to 82°C)

Manual Twist Drain (W) 0 to 250 PSIG (0 to 17.2 bar)

0°F to 150°F (-18°C to 66°C)

Automatic Float Drain 10 to 175 PSIG (0 to 12 bar)

32°F to 150°F (0°C to 66°C)

Note: Air must be dry enough to avoid ice formation at temperatures below 32°F (0°C)

Weight 1.9 lb. (0.85 kg)

Materials of Construction

- Body316 Stainless Steel
- Bowls316 Stainless Steel
- Deflector Acetal
- Drain316 Stainless Steel
- Element Holder Acetal
- Filter Element Polyethylene
- Seals Fluorocarbon
- Sight Gauge Isoplast



PF501 Coalescing Filter – Miniature

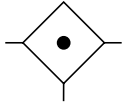

Features

- Stainless steel construction handles most corrosive environments.
- Meets NACE specifications MR-01-75/ISO 15156.
- 1/8" female threaded drain.
- High Flow: 1/4" - 16 SCFM[§]

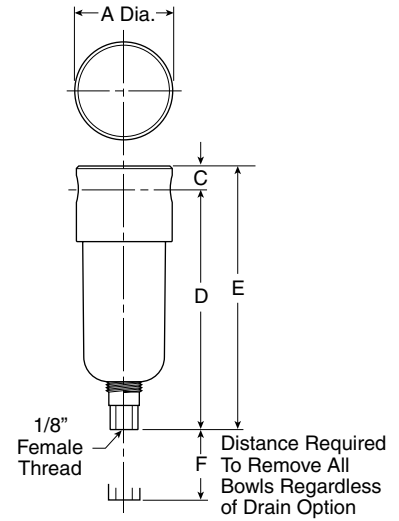

Port Size	NPT	BSPP
	Manual Twist Drain	Manual Twist Drain
1/4"	PF501-02DHSS	PF501G02DHSS

Standard part numbers shown bold. For other models refer to ordering information below.

SCFM = Standard cubic feet per minute at 90 PSIG inlet and 5 PSIG pressure drop.

PF501 Coalescing Filter Dimensions		
A	C	D
1.56 (40)	0.31 (8)	3.69 (94)
E	F	
4.00 (102)	1.58 (40)	

inches
(mm)

Ordering Information

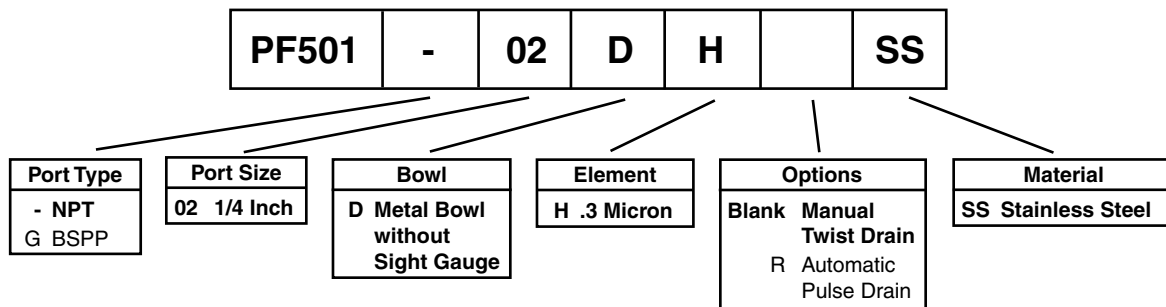

BOLD ITEMS ARE MOST POPULAR.



Operation

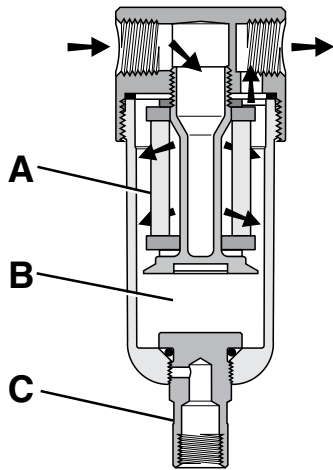

The contaminated air enters the element interior and is forced through a thick membrane (A) of “borosilicate” glass fibers coated with epoxy. Flow then passes through the element, and at this stage 99.97% of the sub micronic particles have been removed from the air stream. The tiny droplets coalesce together and are collected from the filter element by the outer drain layer. The clean, filtered air now passes through and out into the pneumatic system. The air line coalescing filter removes liquid aerosols and sub-micron particulate matter. Collected liquids and particles in the “quiet zone” (B) should be drained before their level reaches a height where they would be reentrained in the flowing air. This can be accomplished by unscrewing the drain valve (C) slightly until the liquid begins to drain.

Technical Information

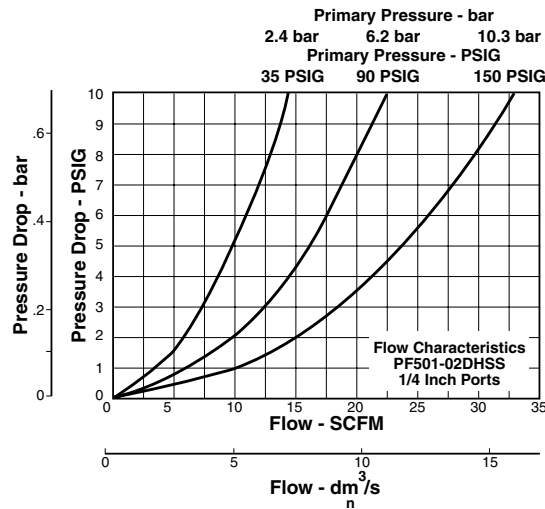

PF501 Filter Kits & Accessories

- Drain Kits –**
- Automatic Pulse Drain RK504SY-SS
- Manual Twist Drain –
- Small (Old) SA600Y7-1SS
- Large (New) SAP05481
- Filter Element Kits –**
- 0.3 Micron..... EKF501H
- Pipe Nipple –**
- 1/4" 316 Stainless Steel 616Y28-SS

Specifications

- Bowl Capacity** 1.0 Ounces
- Filter Rating** 0.3 Micron
- Port Threads** 1/4 Inch

Pressure & Temperature Ratings –

- Manual Twist Drain 0 to 300 PSIG (0 to 20.7 bar)
 0°F to 180°F (-18°C to 82°C)
- Auto Pulse Drain..... 10 to 175 PSIG (0 to 12 bar)
 32°F to 150°F (0°C to 66°C)

Note: Air must be dry enough to avoid ice formation at temperatures below 32°F (0°C)

- Sump Capacity** 0.4 Ounce
- Weight** 0.6 lb. (0.27 kg)

Materials of Construction

- Body** 316 Stainless Steel
- Bowls** 316 Stainless Steel
- Drain** 316 Stainless Steel
- Element Holder** Acetal
- Filter Element** Borosilicate Fiber
- Seals** Fluorocarbon



PF11 Coalescing Filter – Standard

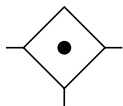

Features

- Stainless steel construction handles most corrosive environments.
- Meets NACE specifications MR-01-75/ISO 15156.
- 1/8" female threaded drain.
- High Flow: 1/2" - 45 SCFM[§]

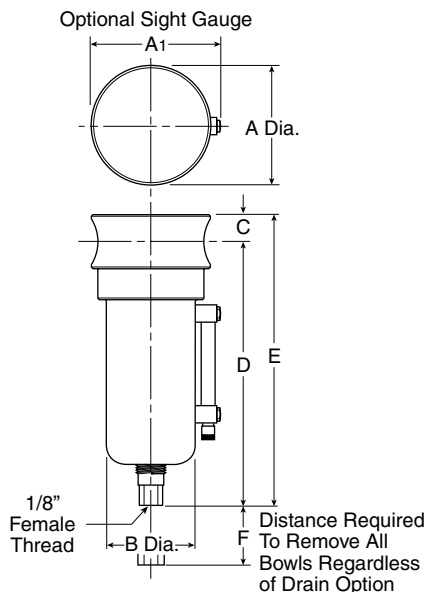

Port Size	NPT		BSPP	
	Manual Twist Drain	Automatic Float Drain	Manual Twist Drain	Automatic Float Drain
1/2"	Metal Bowl With Sight Gauge			
	PF11-04WJSS	PF11-04WJRSS	PF11G04WJSS	PF11G04WJRSS

PF11 Coalescing Filter Dimensions		
A	A1	B
2.38 (60)	2.50 (64)	1.75 (44)
C	D	E
0.56 (14)	5.00 (127)	5.56 (141)
F		
2.12 (54)		

Standard part numbers shown bold. For other models refer to ordering information below.

SCFM = Standard cubic feet per minute at 90 PSIG inlet and 5 PSIG pressure drop.

inches
(mm)

Ordering Information

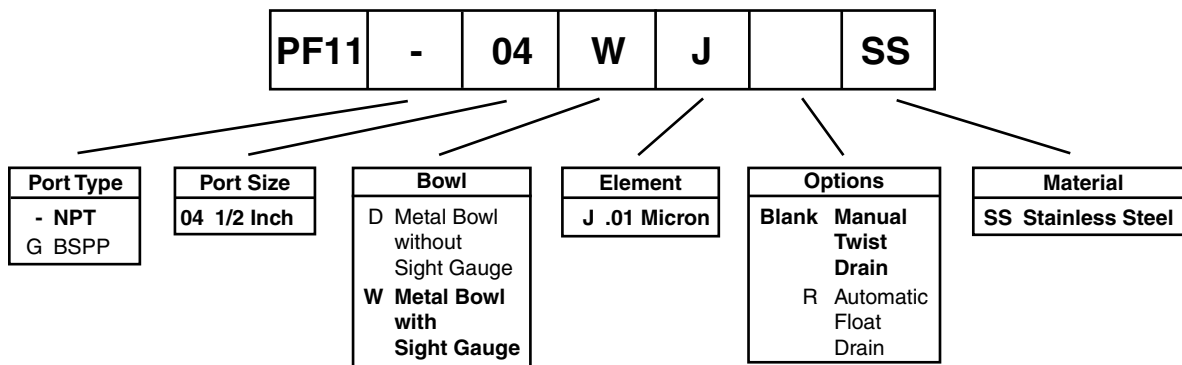

BOLD ITEMS ARE MOST POPULAR.





Operation

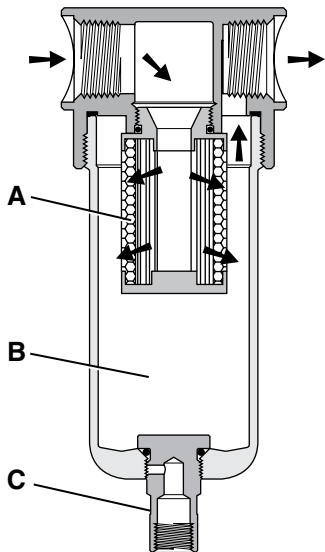

The contaminated air enters the element interior and is forced through a thick membrane (A) of “borosilicate” glass fibers coated with epoxy. Flow then passes through the element, and at this stage 99.97% of the sub micronic particles have been removed from the air stream. The tiny droplets coalesce together and are collected from the filter element by the outer drain layer.

The clean, filtered air now passes through and out into the pneumatic system. The air line coalescing filter removes liquid aerosols and sub-micron particulate matter. Collected liquids and particles in the “quiet zone” (B) should be drained before their level reaches a height where they would be reentrained in the flowing air. This can be accomplished by unscrewing the drain valve (C) slightly until the liquid begins to drain.

Technical Information

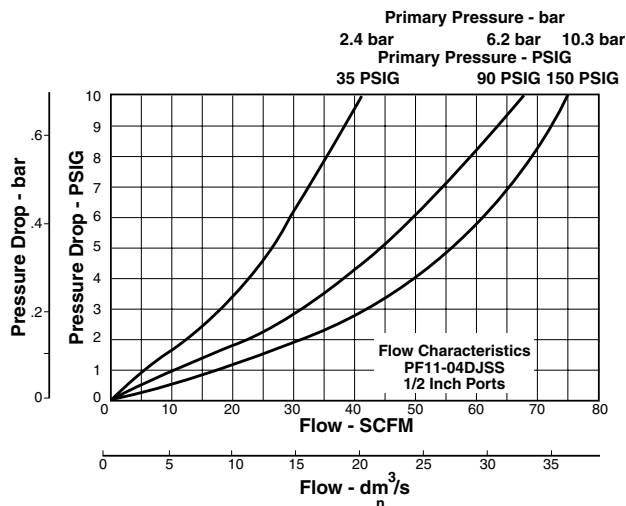

PF11 Filter Kits & Accessories

Drain Kits –

Automatic Float Drain SA10MDSS

Filter Element Kits –

0.01 Micron EKF71

Pipe Nipple –

1/2" 316 Stainless Steel 616A28-SS

Specifications

Bowl Capacity 4.0 Ounces

Filter Rating 0.01 Micron

Sump Capacity 1.7 Ounce

Port Threads 1/2 Inch

Pressure & Temperature Ratings –

Manual Twist Drain 0 to 300 PSIG (0 to 20.7 bar)
0°F to 180°F (-18°C to 82°C)

Manual Twist Drain (W) 0 to 250 PSIG (0 to 17.2 bar)
0°F to 150°F (-18°C to 66°C)

Automatic Float Drain 10 to 175 PSIG (0 to 12 bar)
32°F to 150°F (0°C to 66°C)

Note: Air must be dry enough to avoid ice formation at temperatures below 32°F (0°C)

Weight 1.9 lb. (0.85 kg)

Materials of Construction

Body 316 Stainless Steel

Bowls 316 Stainless Steel

Drain 316 Stainless Steel

Element Holder Acetal

Filter Element Borosilicate Fiber

Seals Fluorocarbon

Sight Gauge Isoplast



PR354, PR364 Regulator – Miniature

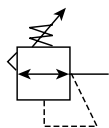

Features

- Stainless steel construction handles most corrosive environments.
- Large diaphragm to valve area ratio for precise regulation and high flow capacity.
- Meets NACE specifications MR-01-75/ISO 15156.
- High Flow: 1/4" – 12 SCFM[§]



PR364



PR354

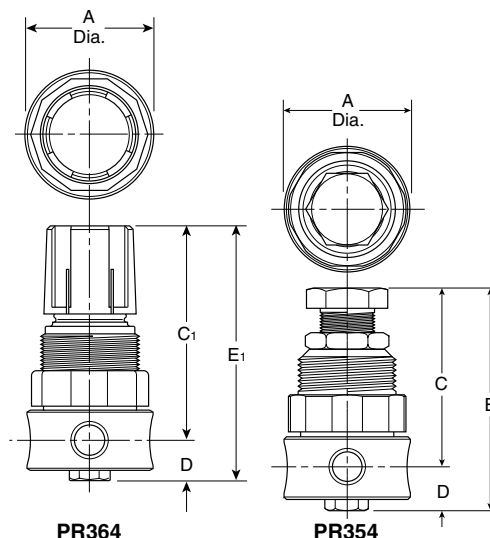

Series	Adjustment Type	Port Size	NPT	BSP
PR364	Knob	1/4"	PR364-02CSS	PR364G02CSS
PR354	All Metal	1/4"	PR354-02CSS	PR354G02CSS

Standard part numbers shown bold. For other models refer to ordering information below.

[§] SCFM = Standard cubic feet per minute at 100 PSIG inlet, 75 PSIG no flow secondary setting and 15 PSIG pressure drop.

PR354, PR364 Regulator Dimensions		
A 1.56 (40)	C 2.00 (51)	C₁ 2.56 (65)
D 0.50 (13)	E 2.50 (64)	E₁ 3.06 (78)

inches (mm)
 NOTE: 1.25 Dia. (32mm) hole required for panel mounting.

⚠ WARNING

**Product rupture can cause serious injury.
 Do not connect regulator to bottled gas.
 Do not exceed maximum primary pressure rating.**

Ordering Information

PR364 - 02 C SS

Series	Port Type	Port Size	Pressure Range	Options	Material
PR354 Stainless Steel PR364 Standard Knob	- NPT G BSPP	02 1/4 Inch	A 0-25 PSIG (0-1.7 bar) B 0-60 PSIG (0-4.1 bar) C 0-125 PSIG (0-8.5 bar)	Blank Relieving K Non-Relieving P Panel Mount Nut	SS Stainless Steel

BOLD ITEMS ARE MOST POPULAR.



Operation

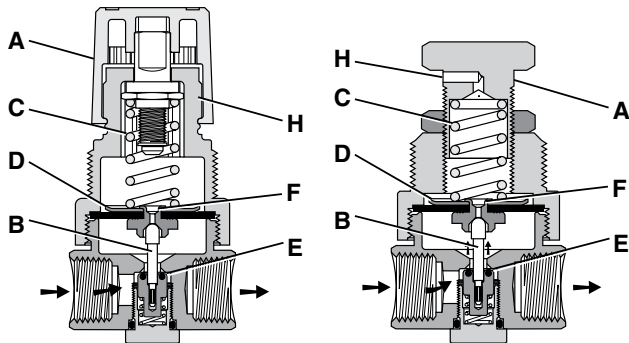

PR364

PR354

With the adjusting knob (A) turned fully counter-clockwise (no spring load), and pressure supplied to the regulator inlet port, the valve poppet assembly (B) is closed. Turning the adjusting knob clockwise applies a load to control spring (C). This load causes the diaphragm (D) and the valve poppet assembly (B) to move downward allowing flow across the seat area (E) created between the poppet assembly and the seat. Pressure in the downstream line is sensed below the diaphragm (D) and offsets the load of spring (C). As downstream pressure rises, poppet assembly (B) and diaphragm (D) move upward until the area (E) is closed and the load of the spring (C) and pressure under diaphragm (D) are in balance. A reduced outlet pressure has now been obtained, depending on spring load. Creating a demand downstream, such as opening a valve, results in a reduced pressure under the diaphragm (D). The load of control spring (C) now causes the poppet assembly to move downward opening seat area (E) allowing air to flow to meet the downstream demand. The flow of downstream air is metered by the amount of opening (E).

Should downstream pressure exceed the desired regulated pressure, the excess pressure will cause the diaphragm (D) to move upward against control spring (C), open vent hole (F), and vent the excess pressure to atmosphere through the hole in the bonnet (H). (This occurs in the relieving type regulator only.)

Technical Information

CAUTION:

REGULATOR PRESSURE ADJUSTMENT –

The working range of knob adjustment is designed to permit outlet pressures within their full range. Pressure adjustment beyond this range is also possible because the knob is not a limiting device. This is a common characteristic of most industrial regulators, and limiting devices may be obtained only by special design.

For best performance, regulated pressure should always be set by increasing the pressure up to the desired setting.

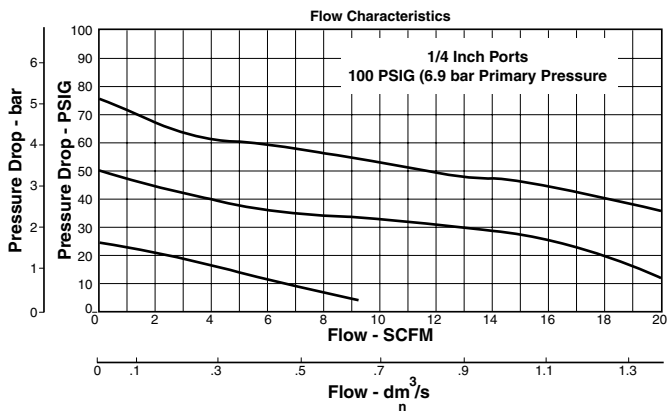

PR354, PR364 Regulator Kits & Accessories

- R354 Bonnet KitCKR354YSS
- PR364 Bonnet Kit (Knob Included)CKR364YSS
- Gauge (Stainless) –
160 PSIG (0 to 1100 kPa), 1-1/2" FaceK4515N14160SS
- Panel Mount Bracket (Stainless) 161X57-SS
- Panel Mount Nut –
Stainless R05X51-SS
Plastic.....R05X51-P
- Pipe Nipple –
1/4" 316 Stainless Steel 616Y28-SS
- Service Kit –
RelievingRKR364YSS
Non-Relieving..... RKR364KYSS
- Springs –
0-25 PSIG RangeSPR-375-2-SS
0-60 PSIG RangeSPR-376-1-SS
0-125 PSIG RangeSPR-377-1-SS

Specifications

Gauge Port 1/4 Inch

- Operation Fluorocarbon Diaphragm
- Port Threads 1/4 Inch
- Pressure & Temperature Ratings –
PR354 300 PSIG Max (20.7 bar)
0°F to 180°F (-18°C to 82°C)
PR364 300 PSIG Max (20.7 bar)
0°F to 150°F (-18°C to 66°C)

Note: Air must be dry enough to avoid ice formation at temperatures below 32°F (0°C)

Weight 0.5 lb. (0.23 kg)

Materials of Construction

- Adjustment Mechanism / Springs316 Stainless Steel
- Adjusting Knob (PR354)316 Stainless Steel
- Adjusting Knob (PR364) Polypropylene
- Body316 Stainless Steel
- Bonnet (PR354)316 Stainless Steel
- Bonnet (PR364) Acetal
- Bottom Plug316 Stainless Steel
- Poppet316 Stainless Steel
- Seals Fluorocarbon





PR10, PR11 Regulator – Standard

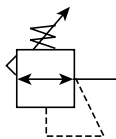

Features

- Stainless steel construction handles most corrosive environments.
- Large diaphragm to valve area ratio for precise regulation and high flow capacity.
- Meets NACE specifications MR-01-75/ISO 15156.
- Low temperature version available.
- High Flow: 1/2" – 80 SCFM[§]



PR11



PR10

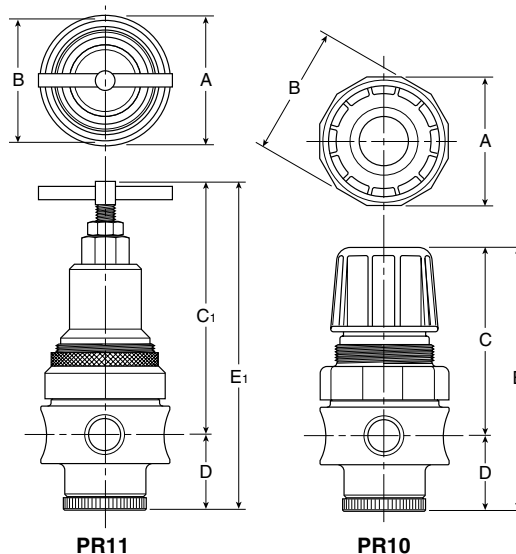

Series	Adjustment Type	Port Size	NPT	BSPB
PR10	Knob	1/2"	PR10-04CSS	PR10G04CSS
PR11	T-Handle	1/2"	PR11-04CSS	PR11G04CSS

PR10, PR11 Regulator Dimensions		
A 2.34 (60)	B 2.43 (62)	C 3.59 (91)
C₁ 4.70 (119)	D 1.38 (35)	E 4.97 (126)
E₁ 6.08 (154)		

Standard part numbers shown bold. For other models refer to ordering information below.

[§] SCFM = Standard cubic feet per minute at 100 PSIG inlet, 75 PSIG no flow secondary setting and 15 PSIG pressure drop.

⚠ WARNING
Product rupture can cause serious injury. Do not connect regulator to bottled gas. Do not exceed maximum primary pressure rating.

inches (mm)
 NOTE: 1.75 Dia. (44mm)
 hole required for panel mounting.

Ordering Information

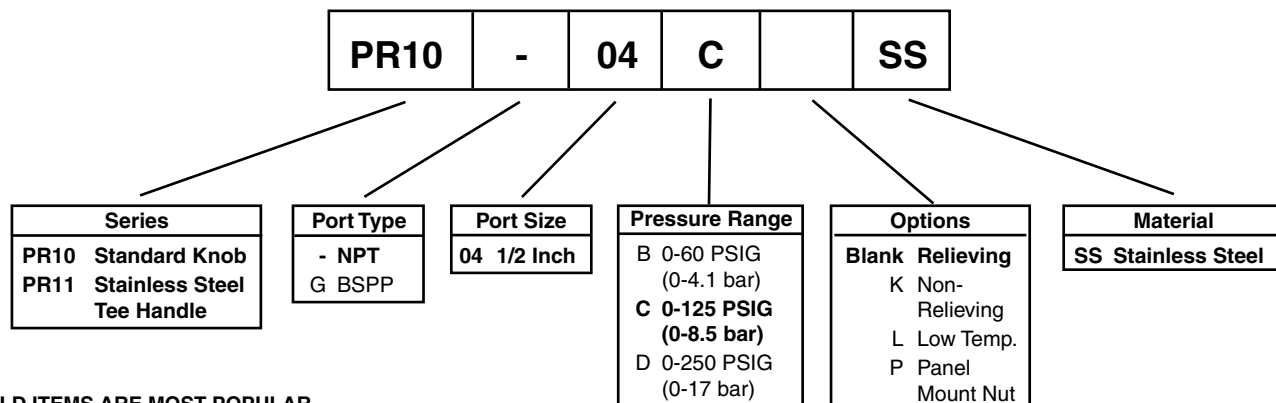

BOLD ITEMS ARE MOST POPULAR.



Operation

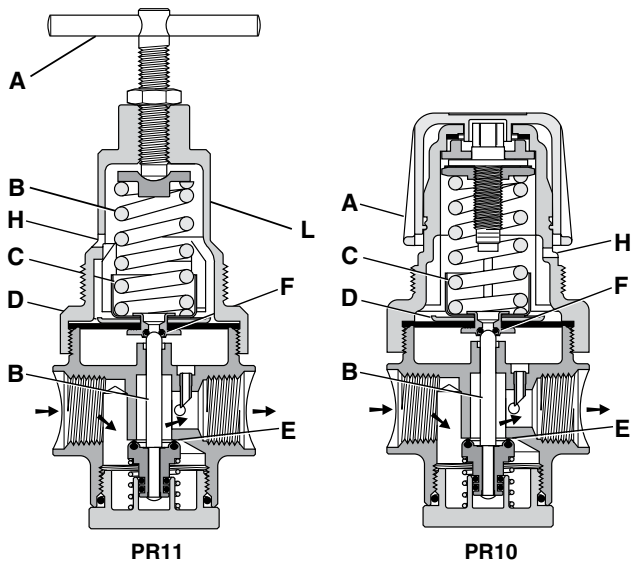

With the adjusting knob / T-Handle (A) turned fully counter-clockwise (no spring load), and pressure supplied to the regulator inlet port, the valve poppet assembly (B) is closed. Turning the adjusting knob clockwise applies a load to control spring (C). This load causes the diaphragm (D) and the valve poppet assembly (B) to move downward allowing flow across the seat area (E) created between the poppet assembly and the seat. Pressure in the downstream line is sensed below the diaphragm (D) and offsets the load of spring (C). As downstream pressure rises, poppet assembly (B) and diaphragm (D) move upward until the area (E) is closed and the load of the spring (C) and pressure under diaphragm (D) are in balance. A reduced outlet pressure has now been obtained, depending on spring load. Creating a demand downstream, such as opening a valve, results in a reduced pressure under the diaphragm (D). The load of control spring (C) now causes the poppet assembly to move downward opening seat area (E) allowing air to flow to meet the downstream demand. The flow of downstream air is metered by the amount of opening (E). Should downstream pressure exceed the desired regulated pressure, the excess pressure will cause the diaphragm (D) to move upward against control spring (C), open vent hole (F), and vent the excess pressure to atmosphere through the hole in the bonnet (H). (This occurs in the relieving type regulator only.)

Technical Information

CAUTION:

REGULATOR PRESSURE ADJUSTMENT –

The working range of knob adjustment is designed to permit outlet pressures within their full range. Pressure adjustment beyond this range is also possible because the knob is not a limiting device. This is a common characteristic of most industrial regulators, and limiting devices may be obtained only by special design.

For best performance, regulated pressure should always be set by increasing the pressure up to the desired setting.

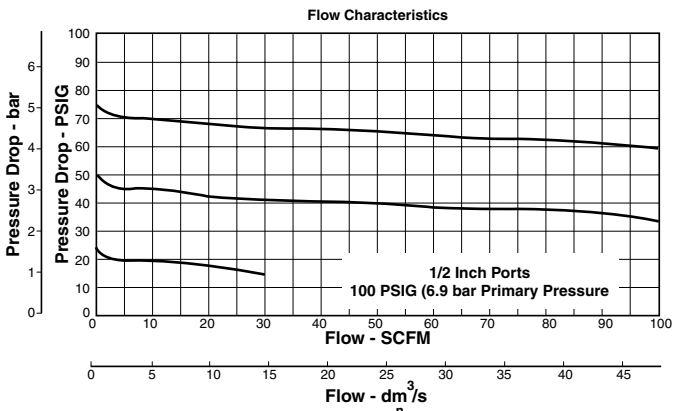

PR10, PR11 Regulator Kits & Accessories

- PR10 Bonnet Kit (Knob Included)CKR10YSS
- PR11 Bonnet KitCKR11YSS
- Gauge (Stainless) –
- 160 PSIG (0 to 1100 kPa), 2" FaceK4520N14160SS
- Panel Mount Bracket (Stainless) 161X57-SS
- Panel Mount Nut –
- Stainless R10X51-SS
- PlasticR10X51-P
- Pipe Nipple –
- 1/2" 316 Stainless Steel 616A28-SS
- Service Kit –
- RelievingRKR10YSS
- Non-Relieving RKR10KYSS
- Springs –
- 0-60 PSIG RangeSPR-388-1-SS
- 0-125 PSIG RangeSPR-389-1-SS
- 0-250 PSIG RangeSPR-390-1-SS

Pressure & Temperature Ratings –

- PR10 300 PSIG Max (20.7 bar)
- 0°F to 150°F (-18°C to 66°C)
- PR11 300 PSIG Max (20.7 bar)
- 0°F to 180°F (-18°C to 82°C)
- Option "L" Minimum Operating Temperature† -40° C/F

Note: Air must be dry enough to avoid ice formation at temperatures below 32°F (0°C)

Weight 1.79 lb. (0.81 kg)

Materials of Construction

- Adjustment Mechanism / Springs316 Stainless Steel
- Body316 Stainless Steel
- Bonnet / Tee Handle (PR11)316 Stainless Steel
- Bonnet / Knob (PR10) Acetal
- Bottom Plug316 Stainless Steel
- Poppet316 Stainless Steel
- Seals Fluorocarbon

† Note: "Low Temperature" option is intended for applications where the ambient temperature may be down to -40° C/F. Air supply must be free of moisture to prevent ice formation and malfunction of units. These units contain EPDM seals. Make sure any oils in the airstream are compatible.

Specifications

- Gauge Port1/4 Inch
- OperationFluorocarbon Diaphragm
- Port Threads 1/2 Inch





PB548, PB558 Filter / Regulator – Miniature

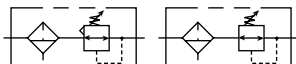

Features

- Stainless steel construction handles most corrosive environments.
- Large diaphragm to valve area ratio for precise regulation and high flow capacity.
- 1/8" female threaded drain.
- Meets NACE specifications MR-01-75/ISO 15156.
- High Flow: 1/4" – 12 SCFM[§]



PB548

PB558

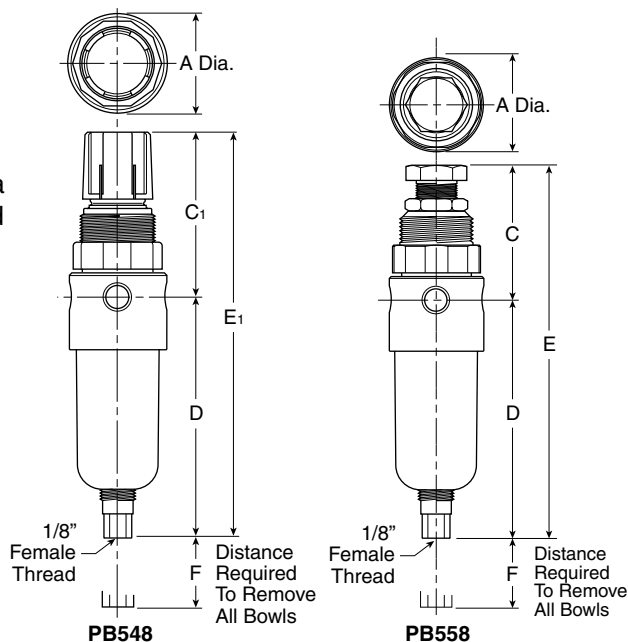

Series	Adjustment Type	Port Size	NPT	BSPB
PB548	Knob	1/4"	PB548-02DHCSS	PB548G02DHCSS
PB558	All Metal	1/4"	PB558-02DHCSS	PB558G02DHCSS

PB548, PB558 Filter / Regulator Dimensions		
A 1.56 (40)	C 2.17 (55)	C₁ 2.63 (67)
D 3.63 (92)	E 5.80 (147)	E₁ 6.26 (159)
F 1.58 (40)		

Standard part numbers shown bold. For other models refer to ordering information below.

[§] SCFM = Standard cubic feet per minute at 100 PSIG inlet, 75 PSIG no flow secondary setting and 15 PSIG pressure drop.

⚠ WARNING

**Product rupture can cause serious injury.
 Do not connect regulator to bottled gas.
 Do not exceed maximum primary pressure rating.**

inches (mm)
 NOTE: 1.25 Dia. (32mm)
 hole required for panel mounting.

Ordering Information

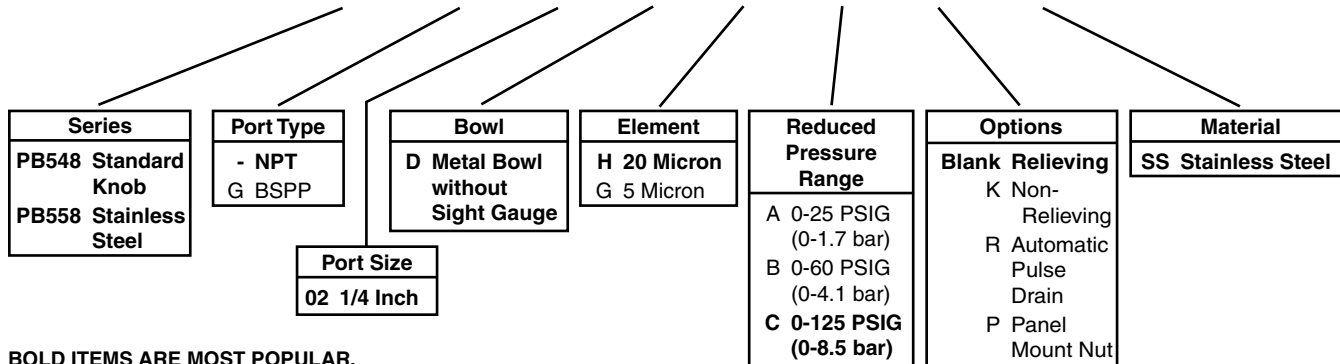
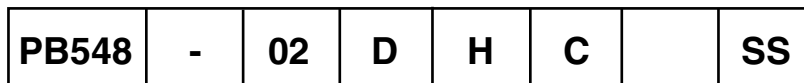

BOLD ITEMS ARE MOST POPULAR.





Operation

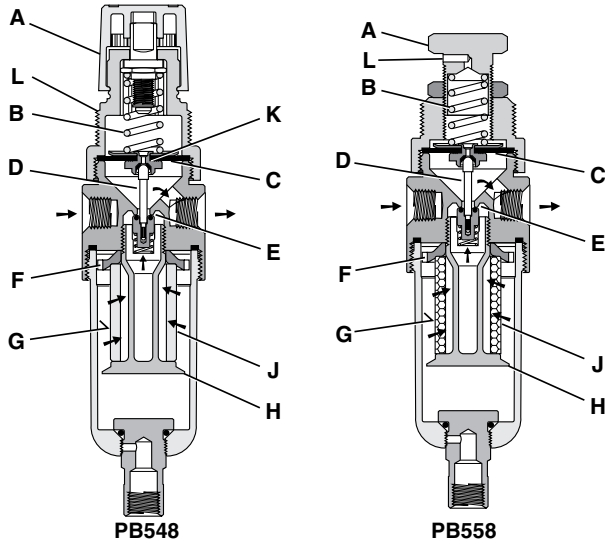

Turning the adjusting knob (A) clockwise applies a load to control spring (B) which forces diaphragm (C) and valve poppet assembly (D) to move downward allowing filtered air to flow through the seat area (E) created between the poppet and the seat. “**First stage filtration**”. Air pressure supplied to the inlet port is directed through deflector plate (F) causing a swirling centrifugal action forcing liquids and coarse particles to the inner bowl wall (G) and down below the lower baffle (H) to the quiet zone. After liquids and large particles are removed in the first stage of filtration “**second stage filtration**” occurs as air flows through element (J) where smaller particles are filtered out and retained. The air flow now passes through seat area (E) to the outlet port of the unit. Pressure in the downstream line is sensed below the diaphragm (C) and offsets the load of spring (B). When downstream pressure reaches the set-point, poppet valve assembly (D) and diaphragm (C) move upward closing seat area (E). Should downstream pressure exceed the desired regulated pressure, the excess pressure will cause the diaphragm (C) to move upward opening vent hole (K) venting the excess pressure to atmosphere through the hole in the bonnet (L). (This occurs in the standard relieving type filter/regulators only.)

Technical Information

CAUTION:

REGULATOR PRESSURE ADJUSTMENT – The working range of knob adjustment is designed to permit outlet pressures within their full range. Pressure adjustment beyond this range is also possible because the knob is not a limiting device. This is a common characteristic of most industrial regulators, and limiting devices may be obtained only by special design.

For best performance, regulated pressure should always be set by increasing the pressure up to the desired setting.

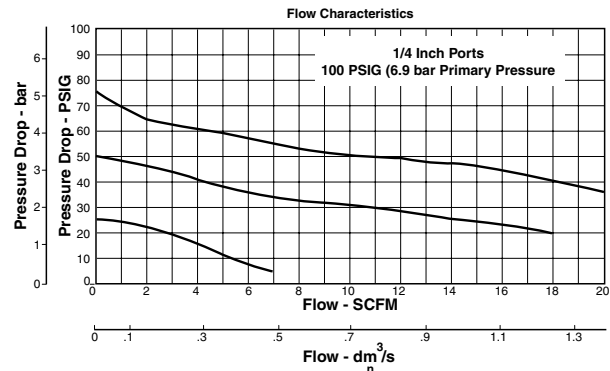

PB548, PB558 Regulator Kits & Accessories

- PB558 Bonnet Kit (Knob Included)CKR354YSS
- PB548 Bonnet Kit (Knob Included)CKR364YSS
- Drain Kit –
 - Automatic Pulse Drain RK504SY-SS
 - Manual Twist Drain–
 - Small (Old) SA600Y7-1SS
 - Large (New) SAP05481
- Filter Element Kits –
 - Particulate (5 Micron) EK504VY
 - Particulate (20 Micron) EK504Y
- Gauge (Stainless) –
 - 160 PSIG (0 to 1100 kPa), 1-1/2" FaceK4515N14160SS
- Panel Mount Bracket (Stainless) 161X57-SS
- Panel Mount Nut –
 - Stainless R05X51-SS
 - Plastic R05X51-P
- Pipe Nipple –
 - 1/4" 316 Stainless Steel 616Y28-SS
- Service Kit –
 - Relieving RK549YSS
 - Non-Relieving RK548YSS
- Springs –
 - 0-25 PSIG Range SPR-375-2-SS
 - 0-60 PSIG Range SPR-376-1-SS
 - 0-125 PSIG Range SPR-377-1-SS

- Filter Rating20 Micron
- Gauge Port1/4 Inch
- OperationFluorocarbon Diaphragm
- Port Threads1/4 Inch
- Pressure & Temperature Ratings –
 - PB548.....300 PSIG Max. (20.7 bar)
0°F to 150°F (-18°C to 82°C)
 - PB558.....300 PSIG Max. (20.7 bar)
0°F to 180°F (-18°C to 82°C)
 - Auto Pulse Drain..... 10 to 175 PSIG (0 to 12 bar)
32°F to 150°F (0°C to 66°C)

Note: Air must be dry enough to avoid ice formation at temperatures below 32°F (2°C)

- Sump Capacity0.4 Ounce
- Weight0.6 lb. (0.27 kg)

Materials of Construction

- Adjustment Mechanism / Springs316 Stainless Steel
- Body316 Stainless Steel
- Bonnet (PB548) Acetal
- Bonnet (PB558)316 Stainless Steel
- Bottom Plug316 Stainless Steel
- Knob (PB548) Polypropylene
- Knob (PB558)316 Stainless Steel
- Poppet316 Stainless Steel
- Seals Fluorocarbon

Specifications

- Bowl Capacity 1.0 Ounces





PB11, PB12 Filter / Regulator – Standard

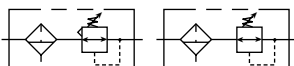

Features

- Stainless steel construction handles most corrosive environments.
- Large diaphragm to valve area ratio for precise regulation and high flow capacity.
- 1/8" female threaded drain.
- Meets NACE specifications MR-01-75/ISO-15156.
- Low temperature version available.
- High Flow: 1/2" – 72 SCFM[§]



PB11



PB12

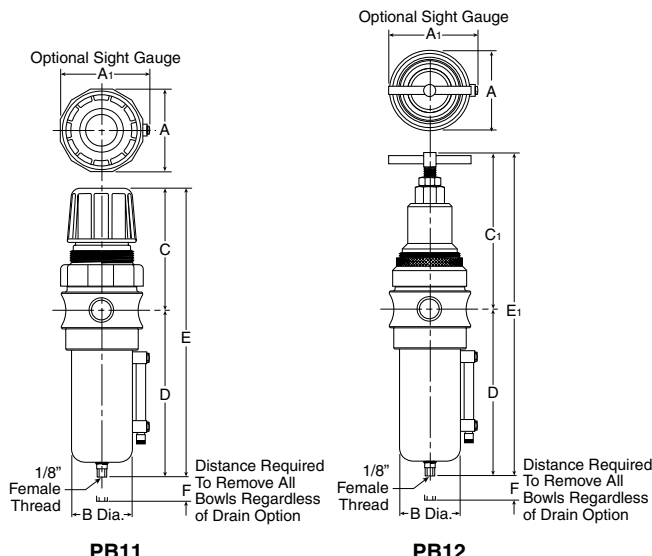

PB11

PB12

Series	Adjustment Type	Port Size	NPT		BSPB	
			Manual Twist Drain	Automatic Float Drain	Manual Twist Drain	Automatic Float Drain
			Metal Bowl with Sight Gauge			
PB11	Knob	1/2"	PB11-04WJCSS	PB11-04WJCRSS	PB11G04WJCSS	PB11G04WJCRSS
PB12	Tee-Handle	1/2"	PB12-04WJCSS	PB12-04WJCRSS	PB12G04WJCSS	PB12G04WJCRSS

PB11, PB12 Filter / Regulator Dimensions		
A 2.34 (60)	A1 2.50 (64)	B 1.75 (44)
C 3.59 (91)	C1 4.70 (119)	D 5.00 (127)
E 8.59 (218)	E1 9.70 (246)	F 2.12 (54)

Standard part numbers shown bold. For other models refer to ordering information below.

[§] SCFM = Standard cubic feet per minute at 100 PSIG inlet, 90 PSIG no flow secondary setting and 15 PSIG pressure drop.

⚠ WARNING
Product rupture can cause serious injury. Do not connect regulator to bottled gas. Do not exceed maximum primary pressure rating.

inches (mm)
 NOTE: 1.75 Dia. (44mm) hole required for panel mounting.

Ordering Information

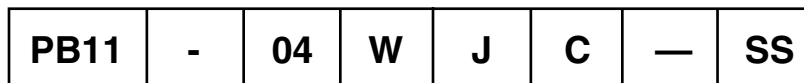

Series	Port Type	Bowl	Element	Reduced Pressure Range	Options	Material
PB11 Standard Knob PB12 Stainless Steel	- NPT G BSPB	D Metal Bowl without Sight Gauge W Metal Bowl with Sight Gauge	J 40 Micron G 5 Micron	B 0-60 PSIG (0-4.1 bar) C 0-125 PSIG (0-8.5 bar) D 0-250 PSIG (0-17 bar)	Blank Relieving K Non-Relieving P Panel Mount Nut R Automatic Float Drain L* Low Temp.	SS Stainless Steel

BOLD ITEMS ARE MOST POPULAR.

* Manual Drain and Without Sight Gauge Only.





Operation

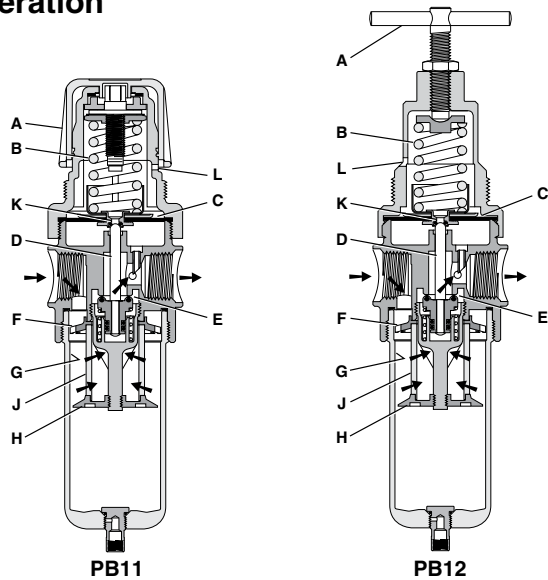

Turning the adjusting knob / T-Handle (A) clockwise applies a load to control spring (B) which forces diaphragm (C) and valve poppet assembly (D) to move downward allowing filtered air to flow through the seat area (E) created between the poppet assembly and the seat. “**First stage filtration**”.

Air pressure supplied to the inlet port is directed through deflector plate (F) causing a swirling centrifugal action forcing liquids and coarse particles to the inner bowl wall (G) and down below the lower baffle (H) to the quiet zone. After liquids and large particles are removed in the first stage of filtration “**second stage filtration**” occurs as air flows through element (J) where smaller particles are filtered out and retained. The air flow now passes through seat area (E) to the outlet port of the unit. Pressure in the downstream line is sensed below the diaphragm (C) and offsets the load of spring (B). When downstream pressure reaches the set-point, poppet valve assembly (D) and diaphragm (C) move upward closing seat area (E). Should downstream pressure exceed the desired regulated pressure, the excess pressure will cause the diaphragm (C) to move upward opening vent hole (K) venting the excess pressure to atmosphere through the hole in the bonnet (L). (This occurs in the standard relieving type filter/regulators only.)

Technical Information

CAUTION:

REGULATOR PRESSURE ADJUSTMENT – The working range of knob adjustment is designed to permit outlet pressures within their full range. Pressure adjustment beyond this range is also possible because the knob is not a limiting device. This is a common characteristic of most industrial regulators, and limiting devices may be obtained only by special design.

For best performance, regulated pressure should always be set by increasing the pressure up to the desired setting.

PB11, PB12 Regulator Kits & Accessories

- PB11 Bonnet Kit (Knob Included)CKR10YSS
- PB12 Bonnet KitCKR11YSS
- Drain Kit –**
- Automatic Float Drain SA10MDSS
- Manual Twist Drain–
- Small (Old) SA600Y7-1SS
- Large (New) SAP05481
- Filter Element Kits –**
- Particulate (40 Micron) EKF10Y
- Particulate (5 Micron) EKF10VY
- Gauge (Stainless) –**
- 160 PSIG (0 to 1100 kPa), 2" FaceK4520N14160SS
- Panel Mount Bracket (Stainless) R10Y57-SS**
- Panel Mount Nut –**
- Stainless R10X51-SS
- Plastic..... R10X51-P
- Pipe Nipple –**
- 1/2" 316 Stainless Steel 616A28-SS
- Service Kit –**
- RelievingRKR10YSS
- Non-Relieving RKR10KYSS
- Springs –**
- 0-60 PSIG RangeSPR-388-1-SS
- 0-125 PSIG RangeSPR-389-1-SS
- 0-250 PSIG RangeSPR-390-1-SS
- Specifications**
- Bowl Capacity** 4.0 Ounces
- Filter Rating**40 Micron

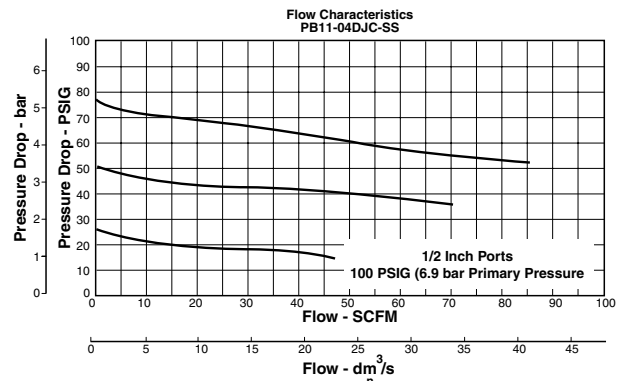

- Gauge Port** 1/4 Inch
- Operation** Fluorocarbon Diaphragm
- Port Threads** 1/2 Inch
- Pressure & Temperature Ratings –**
- PB11 (Metal Bowl D or W) 300 PSIG Max (20.7 bar)
- 0°F to 150°F (-18°C to 66°C)
- PB12 (Metal Bowl D) 300 PSIG Max (20.7 bar)
- 0°F to 180°F (-18°C to 82°C)
- PB12 (Metal Bowl W) 300 PSIG Max (20.7 bar)
- 0°F to 150°F (-18°C to 66°C)
- Automatic Float Drain 15 to 175 PSIG (1 to 12 bar)
- 32°F to 150°F (0°C to 66°C)
- Option “L” Minimum Operating Temperature† -40° C/F
- Note: Air must be dry enough to avoid ice formation at temperatures below 32°F (0°C).**
- Sump Capacity** 1.7 Ounce
- Weight** 2.42 lb. (1.09 kg)
- Materials of Construction**
- Adjustment Mechanism / Springs** 316 Stainless Steel
- Body** 316 Stainless Steel
- Bonnet / Knob (PB11)** Acetal
- Bonnet / Tee Handle (PB12)** 316 Stainless Steel
- Bottom Plug** 316 Stainless Steel
- Poppet** 316 Stainless Steel
- Seals** Fluorocarbon
- Sight Gauge** Isoplast





PL10 Lubricator – Standard



Features

- Stainless Steel Construction Handles Most Corrosive Environments
- 1/8" Female Threaded Drain
- Fillable Under Pressure
- Meets NACE Specifications MR-01-75/ISO 15156
- High Flow: 1/2" - 100 SCFM[§]

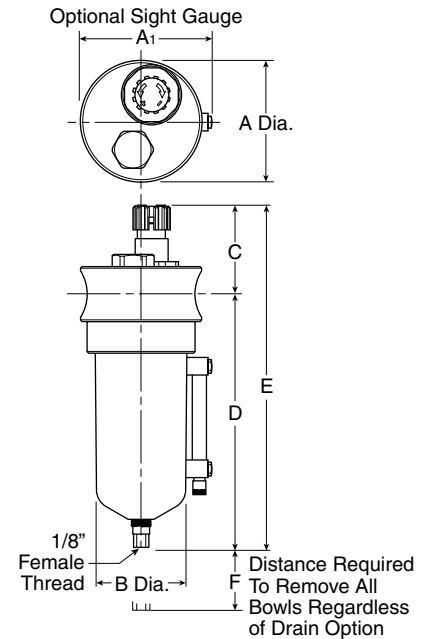

Port Size	NPT	BSPP
	Manual Twist Drain	Manual Twist Drain
1/2"	Metal Bowl With Sight Gauge	
	PL10-04WSS	PL10G04WSS

PL10 Lubricator Dimensions		
A 2.36 (60)	A1 2.52 (64)	B 1.73 (44)
C 2.17 (55)	D 5.46 (139)	E 7.62 (194)
F 3.50 (89)		

Standard part numbers shown bold. For other models refer to ordering information below.

§ SCFM = Standard cubic feet per minute at 90 PSIG inlet and 5 PSIG pressure drop.

inches
(mm)

Ordering Information

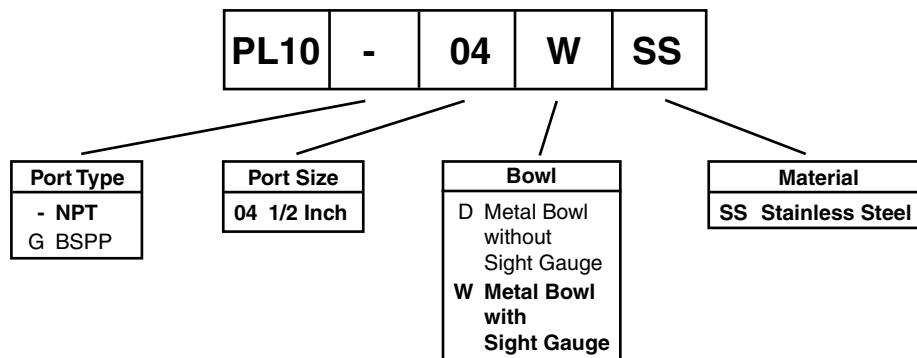

BOLD ITEMS ARE MOST POPULAR.



Operation

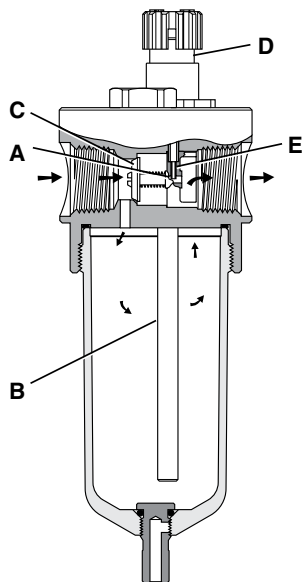

Air flowing through the unit goes through two paths. At low flow rates the majority of the air flows through the Venturi section (A). The rest of the air opens the check valve (C). The velocity of the air flowing through the Venturi section (A) creates a pressure drop. This lower pressure allows the oil to be forced from the reservoir through the pickup tube (B) and travels up to the metering screw (D). The rate of oil delivery is then controlled by adjusting the metering screw (D). Oil flows past the metering screw (D) and forms a drop in the nozzle tube (E). As the oil drops through the dome (F) and back into the Venturi section (A), it is broken up into fine particles. It is then mixed with the air flowing past the check valve (C) and is carried downstream. As the air flow increases the check valve (C) will open more fully. This additional flow will assure that the oil delivery rate will increase linearly with the increase of air flow.

Technical Information

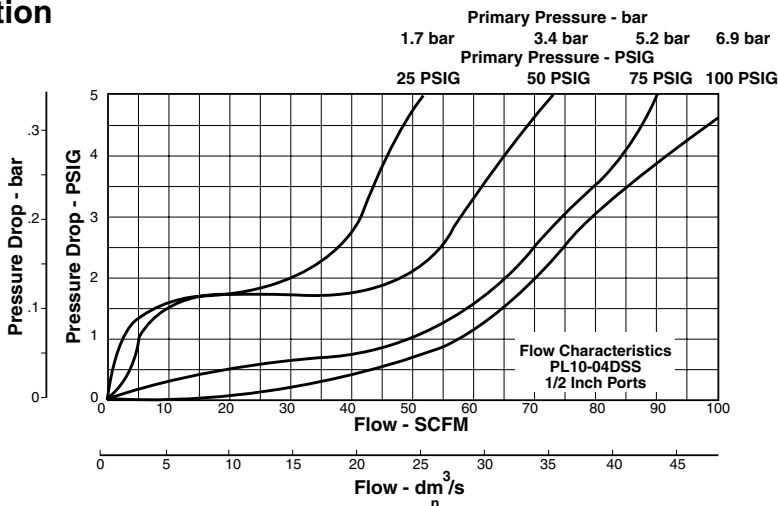

PL10 Filter Kits & Accessories

- Drain Kit –**
 - Manual Twist Drain –
 - Small (Old) SA600Y7-1SS
 - Large (New) SAP05481
- Pipe Nipple –**
 - 1/2" 316 Stainless Steel 616A28-SS
- Sight Dome Kit –**
 - (Old).....RKL10SS
 - (New).....PS740N

Specifications

- Bowl Capacity** 4.0 Ounces
- Port Threads** 1/2 Inch
- Pressure & Temperature Ratings –**
 - Metal Bowl (D) 0 to 300 PSIG (0 to 20.7 bar)
 0°F to 150°F (-18°C to 66°C)
 - Metal Bowl (W) 0 to 250 PSIG (0 to 17.2 bar)
 0°F to 150°F (-18°C to 66°C)

Note: Air must be dry enough to avoid ice formation at temperatures below 32°F (0°C).

Weight 1.9 lb. (0.85 kg)

Materials of Construction

- Body** 316 Stainless Steel
- Bowl** 316 Stainless Steel
- Dip Tube** 316 Stainless Steel
- Drain** 316 Stainless Steel
- Fill Plug** 316 Stainless Steel
- Seals** Fluorocarbon
- Sight Dome** Nylon
- Sight Gauge** Isoplast



Safety Guide For Selecting And Using Pneumatic Division Products And Related Accessories



WARNING:

FAILURE OR IMPROPER SELECTION OR IMPROPER USE OF PNEUMATIC DIVISION PRODUCTS, ASSEMBLIES OR RELATED ITEMS (“PRODUCTS”) CAN CAUSE DEATH, PERSONAL INJURY, AND PROPERTY DAMAGE. POSSIBLE CONSEQUENCES OF FAILURE OR IMPROPER SELECTION OR IMPROPER USE OF THESE PRODUCTS INCLUDE BUT ARE NOT LIMITED TO:

- Unintended or mistimed cycling or motion of machine members or failure to cycle
- Work pieces or component parts being thrown off at high speeds.
- Failure of a device to function properly for example, failure to clamp or unclamp an associated item or device.
- Explosion
- Suddenly moving or falling objects.
- Release of toxic or otherwise injurious liquids or gasses.

Before selecting or using any of these Products, it is important that you read and follow the instructions below.

1. GENERAL INSTRUCTIONS

- 1.1. Scope:** This safety guide is designed to cover general guidelines on the installation, use, and maintenance of Pneumatic Division Valves, FRLs (Filters, Pressure Regulators, and Lubricators), Vacuum products and related accessory components.
- 1.2. Fail-Safe:** Valves, FRLs, Vacuum products and their related components can and do fail without warning for many reasons. Design all systems and equipment in a fail-safe mode, so that failure of associated valves, FRLs or Vacuum products will not endanger persons or property.
- 1.3. Relevant International Standards:** For a good guide to the application of a broad spectrum of pneumatic fluid power devices see: ISO 4414:1998, Pneumatic Fluid Power – General Rules Relating to Systems. See www.iso.org for ordering information.
- 1.4. Distribution:** Provide a copy of this safety guide to each person that is responsible for selection, installation, or use of Valves, FRLs or Vacuum products. Do not select, or use Parker valves, FRLs or vacuum products without thoroughly reading and understanding this safety guide as well as the specific Parker publications for the products considered or selected.
- 1.5. User Responsibility:** Due to the wide variety of operating conditions and applications for valves, FRLs, and vacuum products Parker and its distributors do not represent or warrant that any particular valve, FRL or vacuum product is suitable for any specific end use system. This safety guide does not analyze all technical parameters that must be considered in selecting a product. The user, through its own analysis and testing, is solely responsible for:
 - Making the final selection of the appropriate valve, FRL, Vacuum component, or accessory.
 - Assuring that all user's performance, endurance, maintenance, safety, and warning requirements are met and that the application presents no health or safety hazards.
 - Complying with all existing warning labels and / or providing all appropriate health and safety warnings on the equipment on which the valves, FRLs or Vacuum products are used; and,
 - Assuring compliance with all applicable government and industry standards.
- 1.6. Safety Devices:** Safety devices should not be removed, or defeated.
- 1.7. Warning Labels:** Warning labels should not be removed, painted over or otherwise obscured.
- 1.8. Additional Questions:** Call the appropriate Parker technical service department if you have any questions or require any additional information. See the Parker publication for the product being considered or used, or call 1-800-CPARKER, or go to www.parker.com, for telephone numbers of the appropriate technical service department.

2. PRODUCT SELECTION INSTRUCTIONS

- 2.1. Flow Rate:** The flow rate requirements of a system are frequently the primary consideration when designing any pneumatic system. System components need to be able to provide adequate flow and pressure for the desired application.
- 2.2. Pressure Rating:** Never exceed the rated pressure of a product. Consult product labeling, Pneumatic Division catalogs or the instruction sheets supplied for maximum pressure ratings.
- 2.3. Temperature Rating:** Never exceed the temperature rating of a product. Excessive heat can shorten the life expectancy of a product and result in complete product failure.
- 2.4. Environment:** Many environmental conditions can affect the integrity and suitability of a product for a given application. Pneumatic Division products are designed for use in general purpose industrial applications. If these products are to be used in unusual circumstances such as direct sunlight and/or corrosive or caustic environments, such use can shorten the useful life and lead to premature failure of a product.
- 2.5. Lubrication and Compressor Carryover:** Some modern synthetic oils can and will attack nitrile seals. If there is any possibility of synthetic oils or greases migrating into the pneumatic components check for compatibility with the seal materials used. Consult the factory or product literature for materials of construction.
- 2.6. Polycarbonate Bowls and Sight Glasses:** To avoid potential polycarbonate bowl failures:
 - Do not locate polycarbonate bowls or sight glasses in areas where they could be subject to direct sunlight, impact blow, or temperatures outside of the rated range.
 - Do not expose or clean polycarbonate bowls with detergents, chlorinated hydro-carbons, ketones, esters or certain alcohols.
 - Do not use polycarbonate bowls or sight glasses in air systems where compressors are lubricated with fire resistant fluids such as phosphate ester and di-ester lubricants.

2.7. Chemical Compatibility: For more information on plastic component chemical compatibility see Pneumatic Division technical bulletins Tec-3, Tec-4, and Tec-5

- 2.8. Product Rupture:** Product rupture can cause death, serious personal injury, and property damage.
- Do not connect pressure regulators or other Pneumatic Division products to bottled gas cylinders.
 - Do not exceed the maximum primary pressure rating of any pressure regulator or any system component.
 - Consult product labeling or product literature for pressure rating limitations.

3. PRODUCT ASSEMBLY AND INSTALLATION INSTRUCTIONS

- 3.1. Component Inspection:** Prior to assembly or installation a careful examination of the valves, FRLs or vacuum products must be performed. All components must be checked for correct style, size, and catalog number. DO NOT use any component that displays any signs of nonconformance.
- 3.2. Installation Instructions:** Parker published Installation Instructions must be followed for installation of Parker valves, FRLs and vacuum components. These instructions are provided with every Parker valve or FRL sold, or by calling 1-800-CPARKER, or at www.parker.com.
- 3.3. Air Supply:** The air supply or control medium supplied to Valves, FRLs and Vacuum components must be moisture-free if ambient temperature can drop below freezing

4. VALVE AND FRL MAINTENANCE AND REPLACEMENT INSTRUCTIONS

- 4.1. Maintenance:** Even with proper selection and installation, valve, FRL and vacuum products service life may be significantly reduced without a continuing maintenance program. The severity of the application, risk potential from a component failure, and experience with any known failures in the application or in similar applications should determine the frequency of inspections and the servicing or replacement of Pneumatic Division products so that products are replaced before any failure occurs. A maintenance program must be established and followed by the user and, at minimum, must include instructions 4.2 through 4.10.
- 4.2. Installation and Service Instructions:** Before attempting to service or replace any worn or damaged parts consult the appropriate Service Bulletin for the valve or FRL in question for the appropriate practices to service the unit in question. These Service and Installation Instructions are provided with every Parker valve and FRL sold, or are available by calling 1-800-CPARKER, or by accessing the Parker web site at www.parker.com.
- 4.3. Lockout / Tagout Procedures:** Be sure to follow all required lockout and tagout procedures when servicing equipment. For more information see: OSHA Standard – 29 CFR, Part 1910.147, Appendix A, The Control of Hazardous Energy – (Lockout / Tagout)
- 4.4. Visual Inspection:** Any of the following conditions requires immediate system shut down and replacement of worn or damaged components:
- Air leakage: Look and listen to see if there are any signs of visual damage to any of the components in the system. Leakage is an indication of worn or damaged components.
 - Damaged or degraded components: Look to see if there are any visible signs of wear or component degradation.
 - Kinked, crushed, or damaged hoses. Kinked hoses can result in restricted air flow and lead to unpredictable system behavior.
 - Any observed improper system or component function: Immediately shut down the system and correct malfunction.
 - Excessive dirt build-up: Dirt and clutter can mask potentially hazardous situations.

Caution: Leak detection solutions should be rinsed off after use.

- 4.5. Routine Maintenance Issues:**
- Remove excessive dirt, grime and clutter from work areas.
 - Make sure all required guards and shields are in place.
- 4.6. Functional Test:** Before initiating automatic operation, operate the system manually to make sure all required functions operate properly and safely.
- 4.7. Service or Replacement Intervals:** It is the user's responsibility to establish appropriate service intervals. Valves, FRLs and vacuum products contain components that age, harden, wear, and otherwise deteriorate over time. Environmental conditions can significantly accelerate this process. Valves, FRLs and vacuum components need to be serviced or replaced on routine intervals. Service intervals need to be established based on:
- Previous performance experiences.
 - Government and / or industrial standards.
 - When failures could result in unacceptable down time, equipment damage or personal injury risk.
- 4.8. Servicing or Replacing of any Worn or Damaged Parts:** To avoid unpredictable system behavior that can cause death, personal injury and property damage:
- Follow all government, state and local safety and servicing practices prior to service including but not limited to all OSHA Lockout Tagout procedures (OSHA Standard – 29 CFR, Part 1910.147, Appendix A, The Control of Hazardous Energy – Lockout / Tagout).
 - Disconnect electrical supply (when necessary) before installation, servicing, or conversion.
 - Disconnect air supply and depressurize all air lines connected to system and Pneumatic Division products before installation, service, or conversion.
 - Installation, servicing, and / or conversion of these products must be performed by knowledgeable personnel who understand how pneumatic products are to be applied.
 - After installation, servicing, or conversions air and electrical supplies (when necessary) should be connected and the product tested for proper function and leakage. If audible leakage is present, or if the product does not operate properly, do not put product or system into use.
 - Warnings and specifications on the product should not be covered or painted over. If masking is not possible, contact your local representative for replacement labels.
- 4.9. Putting Serviced System Back into Operation:** Follow the guidelines above and all relevant Installation and Maintenance Instructions supplied with the valve FRL or vacuum component to insure proper function of the system.

The items described in this document and other documents or descriptions provided by Parker Hannifin Corporation, its subsidiaries and its authorized distributors, are hereby offered for sale at prices to be established by Parker Hannifin Corporation, its subsidiaries and its authorized distributors. This offer and its acceptance by any customer ("Buyer") shall be governed by all of the following Terms and Conditions. Buyer's order for any such item, when communicated to Parker Hannifin Corporation, its subsidiaries or an authorized distributor ("Seller") verbally or in writing, shall constitute acceptance of this offer.

1. Terms and Conditions of Sale: All descriptions, quotations, proposals, offers, acknowledgments, acceptances and sales of Seller's products are subject to and shall be governed exclusively by the terms and conditions stated herein. Buyer's acceptance of any offer to sell is limited to these terms and conditions. Any terms or conditions in addition to, or inconsistent with those stated herein, proposed by Buyer in any acceptance of an offer by Seller, are hereby objected to. No such additional, different or inconsistent terms and conditions shall become part of the contract between Buyer and Seller unless expressly accepted in writing by Seller. Seller's acceptance of any offer to purchase by Buyer is expressly conditional upon Buyer's assent to all the terms and conditions stated herein, including any terms in addition to, or inconsistent with those contained in Buyer's offer. Acceptance of Seller's products shall in all events constitute such assent.

2. Payment: Payment shall be made by Buyer net 30 days from the date of delivery of the items purchased hereunder. Amounts not timely paid shall bear interest at the maximum rate permitted by law for each month or portion thereof that the Buyer is late in making payment. Any claims by Buyer for omissions or shortages in a shipment shall be waived unless Seller receives notice thereof within 30 days after Buyer's receipt of the shipment.

3. Delivery: Unless otherwise provided on the face hereof, delivery shall be made F.O.B. Seller's plant. Regardless of the method of delivery, however, risk of loss shall pass to Buyer upon Seller's delivery to a carrier. Any delivery dates shown are approximate only and Seller shall have no liability for any delays in delivery.

4. Warranty: Seller warrants that the items sold hereunder shall be free from defects in material or workmanship for a period of 18 months from date of shipment from Parker Hannifin Corporation. THIS WARRANTY COMPRISES THE SOLE AND ENTIRE WARRANTY PERTAINING TO ITEMS PROVIDED HEREUNDER. SELLER MAKES NO OTHER WARRANTY, GUARANTEE, OR REPRESENTATION OF ANY KIND WHATSOEVER. ALL OTHER WARRANTIES, INCLUDING BUT NOT LIMITED TO, MERCHANTABILITY AND FITNESS FOR PURPOSE, WHETHER EXPRESS, IMPLIED, OR ARISING BY OPERATION OF LAW, TRADE USAGE, OR COURSE OF DEALING ARE HEREBY DISCLAIMED.

NOTWITHSTANDING THE FOREGOING, THERE ARE NO WARRANTIES WHATSOEVER ON ITEMS BUILT OR ACQUIRED WHOLLY OR PARTIALLY, TO BUYER'S DESIGN OR SPECIFICATIONS.

5. Limitation of Remedy: SELLER'S LIABILITY ARISING FROM OR IN ANY WAY CONNECTED WITH THE ITEMS SOLD OR THIS CONTRACT SHALL BE LIMITED EXCLUSIVELY TO REPAIR OR REPLACEMENT OF THE ITEMS SOLD OR REFUND OF THE PURCHASE PRICE PAID BY BUYER, AT SELLER'S SOLE OPTION. IN NO EVENT SHALL SELLER BE LIABLE FOR ANY INCIDENTAL, CONSEQUENTIAL OR SPECIAL DAMAGES OF ANY KIND OR NATURE WHATSOEVER, INCLUDING BUT NOT LIMITED TO LOST PROFITS ARISING FROM OR IN ANY WAY CONNECTED WITH THIS AGREEMENT OR ITEMS SOLD HEREUNDER, WHETHER ALLEGED TO ARISE FROM BREACH OF CONTRACT, EXPRESS OR IMPLIED WARRANTY, OR IN TORT, INCLUDING WITHOUT LIMITATION, NEGLIGENCE, FAILURE TO WARN OR STRICT LIABILITY.

6. Changes, Reschedules and Cancellations: Buyer may request to modify the designs or specifications for the items sold hereunder as well as the quantities and delivery dates thereof, or may request to cancel all or part of this order, however, no such requested modification or cancellation shall become part of the contract between Buyer and Seller unless accepted by Seller in a written amendment to this Agreement. Acceptance of any such requested modification or cancellation shall be at Seller's discretion, and shall be upon such terms and conditions as Seller may require.

7. Special Tooling: A tooling charge may be imposed for any special tooling, including without limitations, dies, fixtures, molds and patterns, acquired to manufacture items sold pursuant to this contract. Such special tooling shall be and remain Seller's property notwithstanding payment of any charges by Buyer. In no event will Buyer acquire any interest in apparatus belonging to Seller which is utilized in the manufacture of the items sold hereunder, even if such apparatus has been specially converted or adapted for such manufacture and notwithstanding any

charges paid by Buyer. Unless otherwise agreed, Seller shall have the right to alter, discard or otherwise dispose of any special tooling or other property in its sole discretion at any time.

8. Buyer's Property: Any designs, tools, patterns, materials, drawings, confidential information or equipment furnished by Buyer, or any other items which become Buyer's property, may be considered obsolete and may be destroyed by Seller after two (2) consecutive years have elapsed without Buyer placing an order for the items which are manufactured using such property. Seller shall not be responsible for any loss or damage to such property while it is in Seller's possession or control.

9. Taxes: Unless otherwise indicated on the face hereof, all prices and charges are exclusive of excise, sales, use, property, occupational or like taxes which may be imposed by any taxing authority upon the manufacture, sale or delivery of the items sold hereunder. If any such taxes must be paid by Seller or if Seller is liable for the collection of such tax, the amount thereof shall be in addition to the amounts for the items sold. Buyer agrees to pay all such taxes or to reimburse Seller therefore upon receipt of its invoice. If Buyer claims exemption from any sales, use or other tax imposed by any taxing authority, Buyer shall save Seller harmless from and against any such tax, together with any interest or penalties thereon which may be assessed if the items are held to be taxable.

10. Indemnity For Infringement of Intellectual Property Rights: Seller shall have no liability for infringement of any patents, trademarks, copyrights, trade dress, trade secrets or similar rights except as provided in this Part 10. Seller will defend and indemnify Buyer against allegations of infringement of U.S. patents, U.S. trademarks, copyrights, trade dress and trade secrets (hereinafter "Intellectual Property Rights"). Seller will defend at its expense and will pay the cost of any settlement or damages awarded in an action brought against Buyer based on an allegation that an item sold pursuant to this contract infringes the Intellectual Property Rights of a third party. Seller's obligation to defend and indemnify Buyer is contingent on Buyer notifying Seller within ten (10) days after Buyer becomes aware of such allegations of infringement, and Seller having sole control over the defense of any allegations or actions including all negotiations for settlement or compromise. If an item sold hereunder is subject to a claim that it infringes the Intellectual Property Rights of a third party, Seller may, at its sole expense and option, procure for Buyer the right to continue using said item, replace or modify said item so as to make it noninfringing, or offer to accept return of said item and return the purchase price less a reasonable allowance for depreciation. Notwithstanding the foregoing, Seller shall have no liability for claims of infringement based on information provided by Buyer, or directed to items delivered hereunder for which the designs are specified in whole or part by Buyer, or infringements resulting from the modification, combination or use in a system of any item sold hereunder. The foregoing provisions of this Part 10 shall constitute Seller's sole and exclusive liability and Buyer's sole and exclusive remedy for infringement of Intellectual Property Rights.

If a claim is based on information provided by Buyer or if the design for an item delivered hereunder is specified in whole or in part by Buyer, Buyer shall defend and indemnify Seller for all costs, expenses or judgments resulting from any claim that such item infringes any patent, trademark, copyright, trade dress, trade secret or any similar right.

11. Force Majeure: Seller does not assume the risk of and shall not be liable for delay or failure to perform any of Seller's obligations by reason of circumstances beyond the reasonable control of Seller (hereinafter "Events of Force Majeure"). Events of Force Majeure shall include without limitation, accidents, acts of God, strikes or labor disputes, acts, laws, rules or regulations of any government or government agency, fires, floods, delays or failures in delivery of carriers or suppliers, shortages of materials and any other cause beyond Seller's control.

12. Entire Agreement/Governing Law: The terms and conditions set forth herein, together with any amendments, modifications and any different terms or conditions expressly accepted by Seller in writing, shall constitute the entire Agreement concerning the items sold, and there are no oral or other representations or agreements which pertain thereto. This Agreement shall be governed in all respects by the law of the State of Ohio. No actions arising out of sale of the items sold hereunder or this Agreement may be brought by either party more than two (2) years after the cause of action accrues.



Parker Hannifin Corporation

Pneumatic Division

8676 E. M89

P.O. Box 901

Richland, MI 49083 USA

Tel: 269 629 5000

Fax: 269 629 5385

Applications Engineering

Phone: 877 321 4PDN Option #2

E-mail: pdnapps@parker.com

Customer Support

Phone: 877 321 4PDN Option #1

E-mail: pdncustsvc@parker.com

Web site: www.parker.com/pneumatics

